

# KA3842AC/KA3842AE SMPS Controller

## Features

- Low start current 0.2mA (Typ.)
- Operating range up to 500kHz
- Cycle by cycle current limiting
- Under Voltage Lock Out (UVLO) with hysteresis
- Short shutdown delay time: Typ.100ns
- High current totem-pole output
- Output swing limiting: 22V

## Description

The KA3842AC/KA3842AE are fixed PWM controllers for Off Line and DC to DC converter applications. The internal circuits include UVLO, low start up current, temperature compensated reference, high gain error amplifier, current sensing comparator, and high current totem pole output for driving a POWER MOSFET. Also KA3842AC/KA3842AE provides low start up current below 0.3mA and short shutdown delay time, typically 100ns. The KA3842AC/KA3842AE has a UVLO threshold of 16V(on) and 10V(off). The KA3842AC/KA3842AE can operate within a 100% duty cycle.



## Ordering Information

Part Number	Operating Temp. Range	Pb-Free	Package	Packing Method
KA3842AC	-0 to +70°C	Yes	8-DIP	Tube
KA3842AE				

Internal Block Diagram

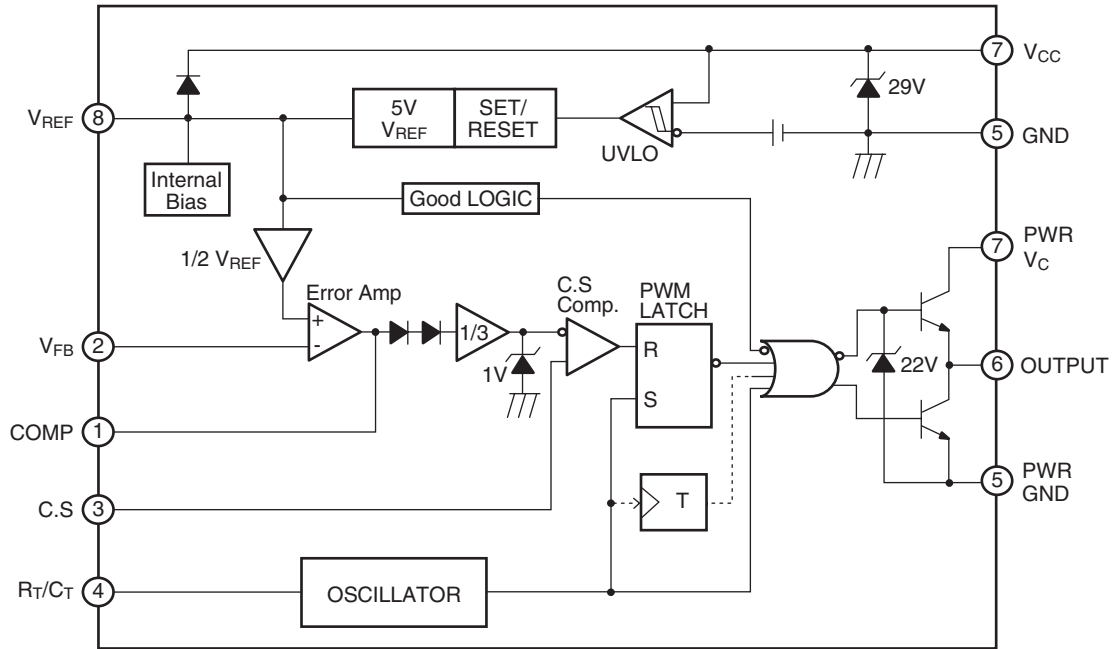

## Absolute Maximum Ratings

The “Absolute Maximum Ratings” are those values beyond which the safety of the device cannot be guaranteed. The device should not be operated at these limits. The parametric values defined in the Electrical Characteristics tables are not guaranteed at the absolute maximum ratings. The “Recommended Operating Conditions” table will define the conditions for actual device operation.

Symbol	Parameter	Value	Unit
$V_{CC}$	Supply Voltage	30	V
$I_O$	Output Current	$\pm 1$	A
$V_{I(ANA)}$	Analog Inputs (Pins 2, 3)	-0.3 to 6.3	V
$I_{SINK(EA)}$	Error Amp. Output Sink Current	10	mA
$P_D$	Power Dissipation	1	W
$R\theta_{ja}$	Thermal Resistance, Junction-to-Air <sup>(4)</sup>	95	$^{\circ}C/W$

## Electrical Characteristics

( $V_{CC} = 15V$ ,  $R_T = 10k^{\frac{3}{4}}$ ,  $C_T = 3.3nF$ ,  $T_A = 0^{\circ}C$  to  $+70^{\circ}C$ , unless otherwise specified)

Symbol	Parameter	Conditions	Min.	Typ.	Max.	Unit
<b>REFERENCE SECTION</b>						
$V_{REF}$	Output Voltage	$T_J = 25^{\circ}C$ , $I_O = 1mA$	4.9	5.0	5.1	V
$\Delta V_{REF}$	Line Regulation	$V_{CC} = 12V$ to $25V$	–	6	20	mV
	Load Regulation	$I_O = 1mA$ to $20mA$	–	6	25	mV
$I_{SC}$	Output Short Circuit	$T_A = 25^{\circ}C$	–	-100	-180	mA
<b>OSILLATOR SECTION</b>						
$F_{OSC}$	Initial Accuracy	$T_J = 25^{\circ}C$	47	52	57	kHz
$ST_V$	Voltage Stability	$V_{CC} = 12V$ to $25V$	–	0.2	1	%
$V_{OSC}$	Amplitude	$V_{PIN4}$ , Peak to Peak	–	1.7	–	V
$I_{DISCHG}$	Discharge Current	$T_J = 25^{\circ}C$ , Pin 4 = 2V	7.8	8.3	8.8	mA
<b>CURRENT SENSE SECTION</b>						
$G_V$	Gain <sup>(2)(3)</sup>		2.85	3	3.15	V/V
$V_{I(MAX)}$	Maximum Input Signal <sup>(2)</sup>	$V_{PIN1} = 5V$	0.9	1.0	1.1	V
PSRR	PSRR <sup>(1)(2)</sup>	$V_{CC} = 12V$ to $25V$	–	70	–	dB
$I_{BIAS}$	Input Bias Current		–	-2	-10	$\mu A$
$T_D$	Delay to Output <sup>(1)</sup>	$V_{PIN3} = 0V$ to $2V$	–	100	200	ns
<b>ERROR AMPLIFIER SECTION</b>						
$V_I$	Input Voltage	$T_{PIN1} = 2.5V$	2.42	2.50	2.58	V
$I_{BIAS}$	Input Bias Current		–	-0.3	-2	$\mu A$
$G_{VO}$	Open Loop Gain <sup>(1)</sup>	$V_O = 2V$ to $4V$	65	90	–	dB
GBW	Unity Gain Bandwidth <sup>(1)</sup>	$T_J = 25^{\circ}C$	0.7	1	–	MHz
PSRR	PSRR <sup>(1)</sup>	$V_{CC} = 12V$ to $25V$	60	70	–	dB
$I_{SINK}$	Output Sink Current	$V_{PIN2} = 2.7V$ $V_{PIN1} = 1.1V$	2	6	–	mA
$I_{SOURCE}$	Output Source Current	$V_{PIN2} = 2.3V$ $V_{PIN1} = 5.0V$	-0.5	-0.8	–	mA
$V_{OH}$	Output High Voltage	$V_{PIN2} = 2.3V$ , $R1 = 15k^{\frac{3}{4}}$ to GND	5	6	–	V
$V_{OL}$	Output Low Voltage	$V_{PIN2} = 2.7V$ $R1 = 15k^{\frac{3}{4}}$ to Pin 8	–	0.8	1.1	V

**Electrical Characteristics** (Continued)(V<sub>CC</sub> = 15V, R<sub>T</sub> = 10k<sup>3/4</sup>, C<sub>T</sub> = 3.3nF, T<sub>A</sub> = 0°C to +70°C, unless otherwise specified)

Symbol	Parameter	Conditions	Min.	Typ.	Max.	Unit
<b>OUTPUT SECTION</b>						
V <sub>OL</sub>	Output Low Level	I <sub>SINK</sub> = 20mA	–	0.1	0.4	V
		I <sub>SINK</sub> = 200mA	–	1.5	2.2	V
V <sub>OH</sub>	Output High Level	I <sub>SOURCE</sub> = 20mA	13	13.5	–	V
		I <sub>SOURCE</sub> = 200mA	12	13.5	–	V
t <sub>R</sub>	Rise Time <sup>(1)</sup>	T <sub>J</sub> = 25°C, C <sub>1</sub> = 1nF	–	40	100	ns
t <sub>F</sub>	Fall Time <sup>(1)</sup>	T <sub>J</sub> = 25°C, C <sub>1</sub> = 1nF	–	40	100	ns
V <sub>OLIM</sub>	Output Voltage Swing Limit	V <sub>CC</sub> = 27V, C <sub>1</sub> = 1nF	–	22	–	V
<b>UNDER VOLTAGE LOCKOUT SECTION</b>						
V <sub>TH</sub>	Start Threshold		15	16	17	V
V <sub>TL</sub>	Min. Operating Voltage (After turn on)		9	10	11	V
<b>PWM SECTION</b>						
D <sub>MAX</sub>	Maximum Duty Cycle		94	96	100	%
D <sub>MIN</sub>	Minimum Duty Cycle		–	–	0	%
<b>TOTAL STANDBY CURRENT</b>						
I <sub>ST</sub>	Start-Up Current		–	0.2	0.4	mA
I <sub>CC</sub>	Operating Supply Current	V <sub>PIN2</sub> = V <sub>PIN3</sub> = 0V	–	11	17	mA
V <sub>Z</sub>	V <sub>CC</sub> Zener Voltage	I <sub>CC</sub> = 25mA	–	29	–	V

\* Adjust V<sub>CC</sub> above the start threshold before setting at 15V**Notes:**

1. These parameters, although guaranteed, are not 100% tested in production.
2. Parameter measured at trip point of latch with V<sub>2</sub> = 0V.
3. Gain defined as:  $G_V = \Delta V_{PIN1} / \Delta V_{PIN3}$  (V<sub>PIN3</sub> = 0 to 0.8V)
4. Junction-to-air thermal resistance test environments

## PCB information:

Board thickness; 1.6mm, Board dimension: 76.2 X 114.3mm<sup>2</sup>, Ref.: EIA/JSED51-3 and EIA/JSED51-7  
 Board structure; Using the single layer PCB.

# Package Dimensions

## 8-Pin DIP

Dimensions in millimeters

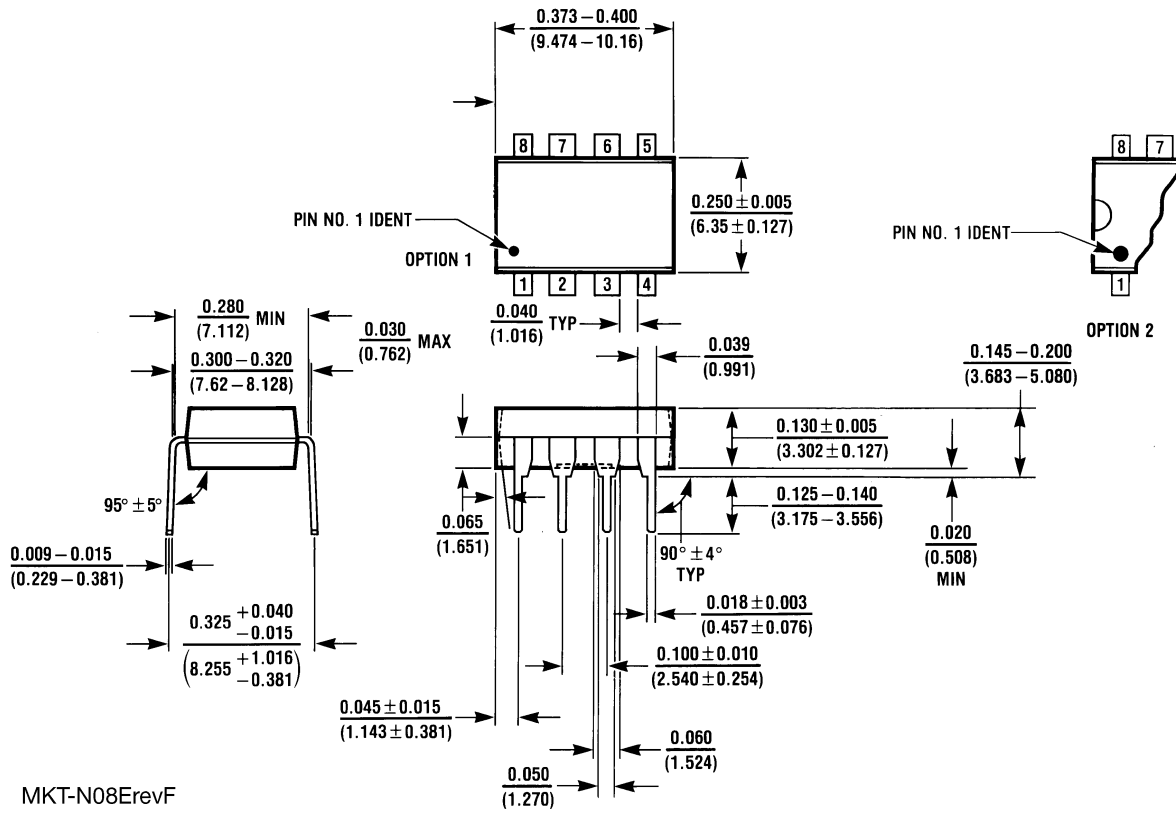

**TRADEMARKS**

The following are registered and unregistered trademarks Fairchild Semiconductor owns or is authorized to use and is not intended to be an exhaustive list of all such trademarks.

ACEx™	FAST®	ISOPLANAR™	PowerSaver™	SuperSOT™-6
ActiveArray™	FASTr™	LittleFET™	PowerTrench®	SuperSOT™-8
Bottomless™	FPS™	MICROCOUPLER™	QFET®	SyncFET™
Build it Now™	FRFET™	MicroFET™	QS™	TCM™
CoolFET™	GlobalOptoisolator™	MicroPak™	QT Optoelectronics™	TinyLogic®
CROSSVOLT™	GTO™	MICROWIRE™	Quiet Series™	TINYOPTO™
DOME™	HiSeC™	MSX™	RapidConfigure™	TruTranslation™
EcoSPARK™	I <sup>2</sup> C™	MSXPro™	RapidConnect™	UHC™
E <sup>2</sup> CMOS™	i-Lo™	OCX™	µSerDes™	UltraFET®
EnSigna™	ImpliedDisconnect™	OCXPro™	ScalarPump™	UniFET™
FACT™	IntelliMAX™	OPTOLOGIC®	SILENT SWITCHER®	VCX™
FACT Quiet Series™		OPTOPLANAR™	SMART START™	Wire™
Across the board. Around the world.™		PACMAN™	SPM™	
The Power Franchise®		POP™	Stealth™	
Programmable Active Droop™		Power247™	SuperFET™	
		PowerEdge™	SuperSOT™-3	

**DISCLAIMER**

FAIRCHILD SEMICONDUCTOR RESERVES THE RIGHT TO MAKE CHANGES WITHOUT FURTHER NOTICE TO ANY PRODUCTS HEREIN TO IMPROVE RELIABILITY, FUNCTION OR DESIGN. FAIRCHILD DOES NOT ASSUME ANY LIABILITY ARISING OUT OF THE APPLICATION OR USE OF ANY PRODUCT OR CIRCUIT DESCRIBED HEREIN; NEITHER DOES IT CONVEY ANY LICENSE UNDER ITS PATENT RIGHTS, NOR THE RIGHTS OF OTHERS.

**LIFE SUPPORT POLICY**

FAIRCHILD'S PRODUCTS ARE NOT AUTHORIZED FOR USE AS CRITICAL COMPONENTS IN LIFE SUPPORT DEVICES OR SYSTEMS WITHOUT THE EXPRESS WRITTEN APPROVAL OF FAIRCHILD SEMICONDUCTOR CORPORATION. As used herein:

- |   |   |
|---|---|
| <p>1. Life support devices or systems are devices or systems which, (a) are intended for surgical implant into the body, or (b) support or sustain life, or (c) whose failure to perform when properly used in accordance with instructions for use provided in the labeling, can be reasonably expected to result in significant injury to the user.</p> | <p>2. A critical component is any component of a life support device or system whose failure to perform can be reasonably expected to cause the failure of the life support device or system, or to affect its safety or effectiveness.</p> |
|---|---|

**PRODUCT STATUS DEFINITIONS**

**Definition of Terms**

Datasheet Identification	Product Status	Definition
Advance Information	Formative or In Design	This datasheet contains the design specifications for product development. Specifications may change in any manner without notice.
Preliminary	First Production	This datasheet contains preliminary data, and supplementary data will be published at a later date. Fairchild Semiconductor reserves the right to make changes at any time without notice in order to improve design.
No Identification Needed	Full Production	This datasheet contains final specifications. Fairchild Semiconductor reserves the right to make changes at any time without notice in order to improve design.
Obsolete	Not In Production	This datasheet contains specifications on a product that has been discontinued by Fairchild semiconductor. The datasheet is printed for reference information only.

Rev. 118